

Hot Water Circulating Pumps Standard Programme

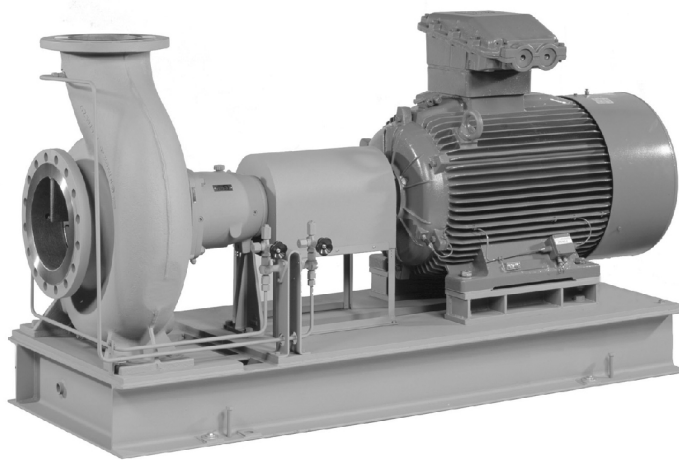

Automation products available:

- Hyamaster
- hyatronic

Fields of Application

HPK pumps in standard design are used for plants where hot water thermal oils must be transported in pipeline or tank systems, particularly in medium-sized and large heating systems, forced circulation boilers, district heating systems and similar. HPK-E and HPK-E4 have been type-tested to TRD (German Steam Boiler Regulations) by TÜV (Technical Control Board). Type test certificates can be offered and supplied on request.

Design

Horizontal, radially split volute casing pump in back pull-out design with radial impeller, single-entry, single-stage, in accordance with EN 22 858/ISO 2858/ISO 5199. Complemented by pump sizes DN 25 and DN 200 to DN 400.

Designation

Type series _____ HPK - S M 40-200
 Material of wetted parts _____
 Additional code _____
 Discharge nozzle DN _____
 Nominal impeller diameter in mm _____
 Additional codes:
 M = mechanical seal
 x = uncooled shaft seal chamber

Operating Data

Pump sizes DN 25 to 400
 Capacities Q up to 4.800 m³/h (1.330 l/s)
 Heads H up to 275 m
 Operating pressures p up to 25 bar (-S/-E) 40 bar (-E4)
 Operating temperatures t up to +240 °C (hot water)
 +400 °C (thermal oils - on request!)

Certification

Certified quality management ISO 9001.

Materials

Part No.	Description	HPK - S / Sx	HPK - E / Ex	HPK - E4
102	Volute casing	JS1025 ³⁾	GP240GH+N	1.7706
161	Casing cover	P250GH	P250GH	P250GH
183	Support foot	S235JRG2 ¹⁾	S235JRG2 ¹⁾	S235JRG2 ¹⁾
210	Shaft	C45+N	C45+N	C45+N
230	Impeller	JL1040 ²⁾⁴⁾	JL1040 ²⁾⁴⁾	JL1040 ²⁾⁴⁾
330	Bearing bracket	JL1040 ²⁾⁴⁾	JL1040 ²⁾⁴⁾	JL1040 ²⁾⁴⁾
344	Bearing bracket lantern	JS1025 ³⁾	JS1025 ³⁾	JS1025 ³⁾
452.01	Gland	1.4571	1.4571	1.4571
454.01	Stuffing box ring	1.4571	1.4571	1.4571
471.01	Seal cover	C22+N	C22+N	C22+N
502.01	Casing wear ring	JL1040 ⁴⁾	--	--
524.01	Shaft protecting sleeve (gland packing)	1.4122 hardened	1.4122 hardened	1.4122 hardened
524.01	Shaft protecting sleeve (mechanical seal)	1.4571	1.4571	1.4571
922	Impeller nut	1.4571	1.4571	1.4571

1) for bearing bracket P 05s and above: GJS-400-15

2) for pumps with bearing bracket P 04: GJS-400-15; for all other bearing brackets, if $v_u > 48$ m/s: 1.4408

3) GJS-400-18-LT to EN 1563

4) GJL-250 to EN 1561

Selection Charts

n = 2900 rpm

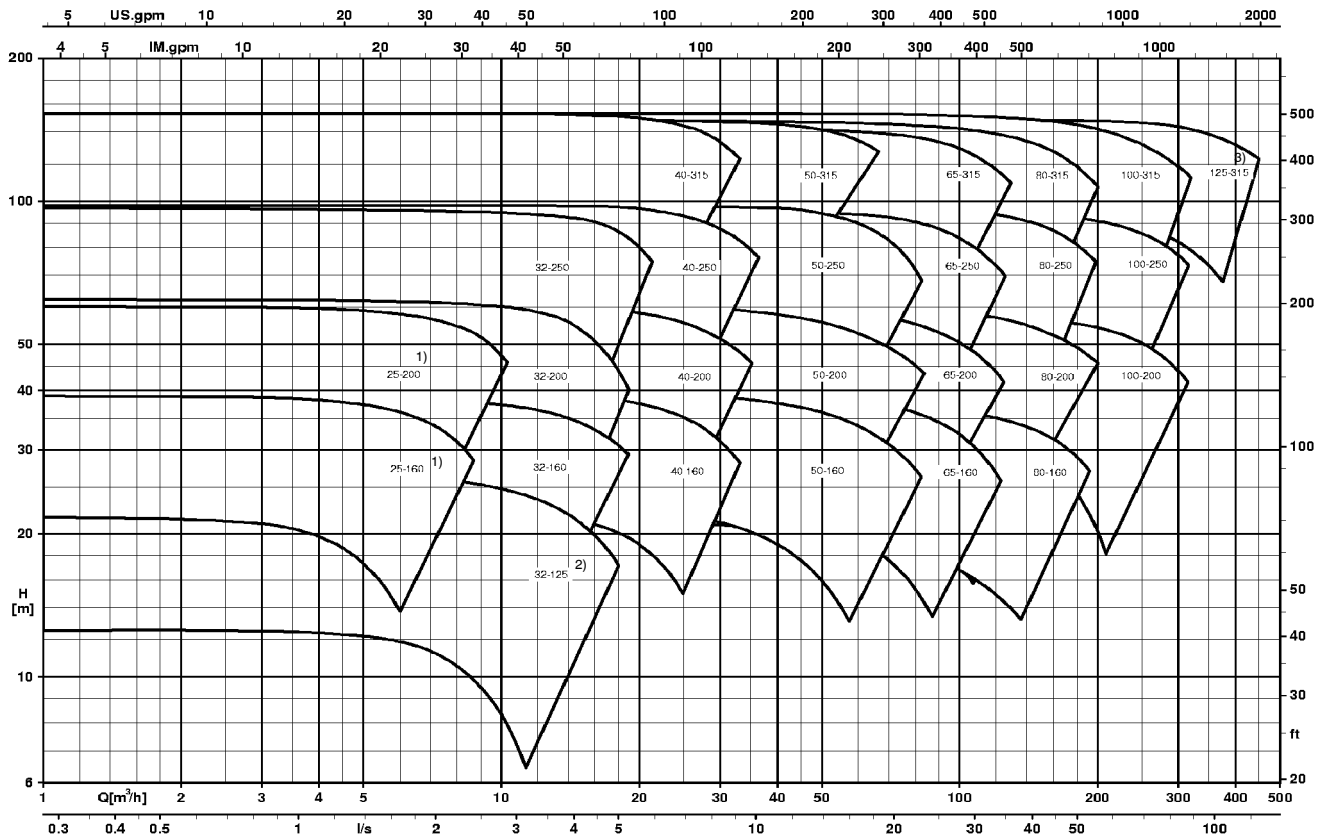

n = 1450 rpm

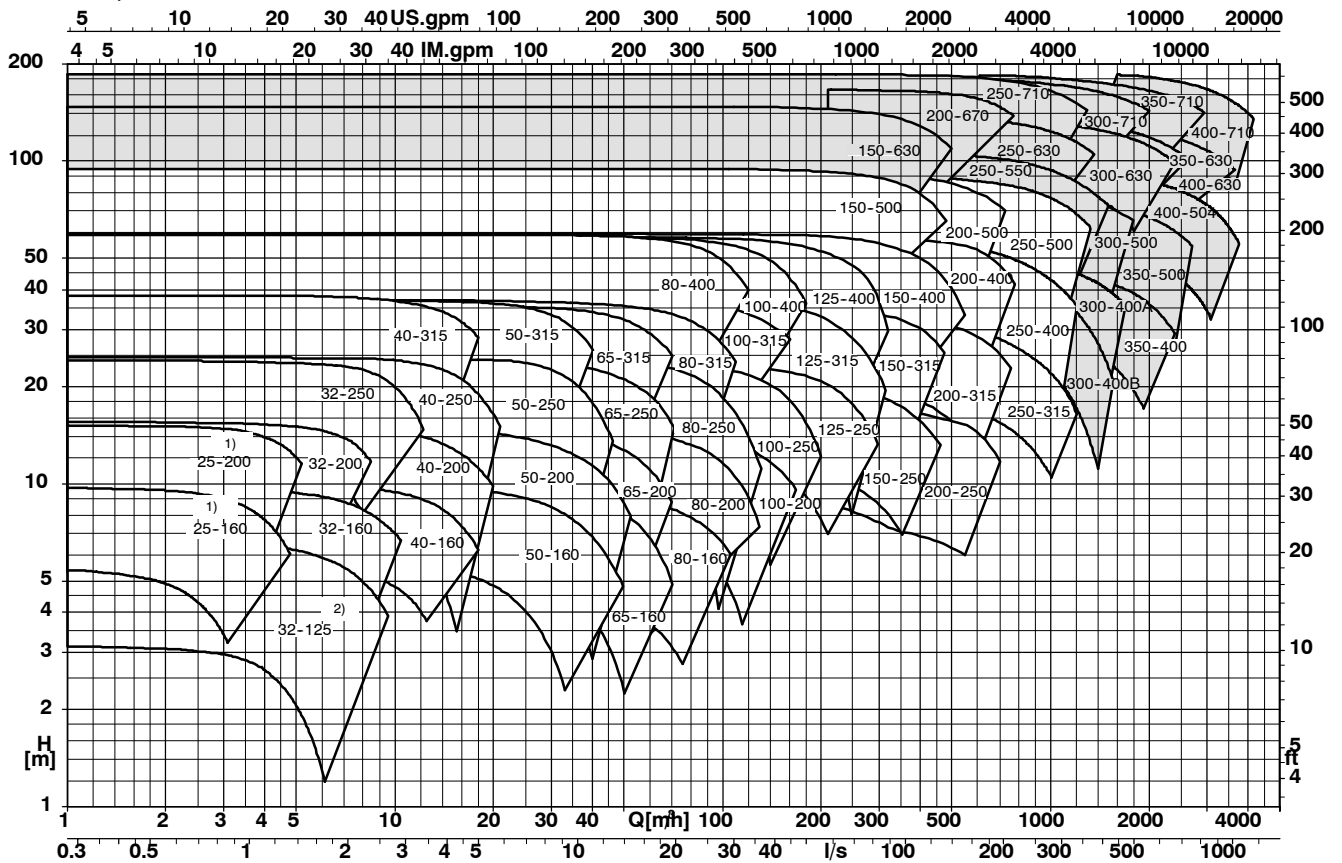

Complementary sizes on request

1121C.4054/4

- 1) HPK-S/-E4 not available in this size
- 2) HPK-E/-E4 not available in this size
- 3) available as HPK-E4 only

Selection Charts

n = 3500 rpm

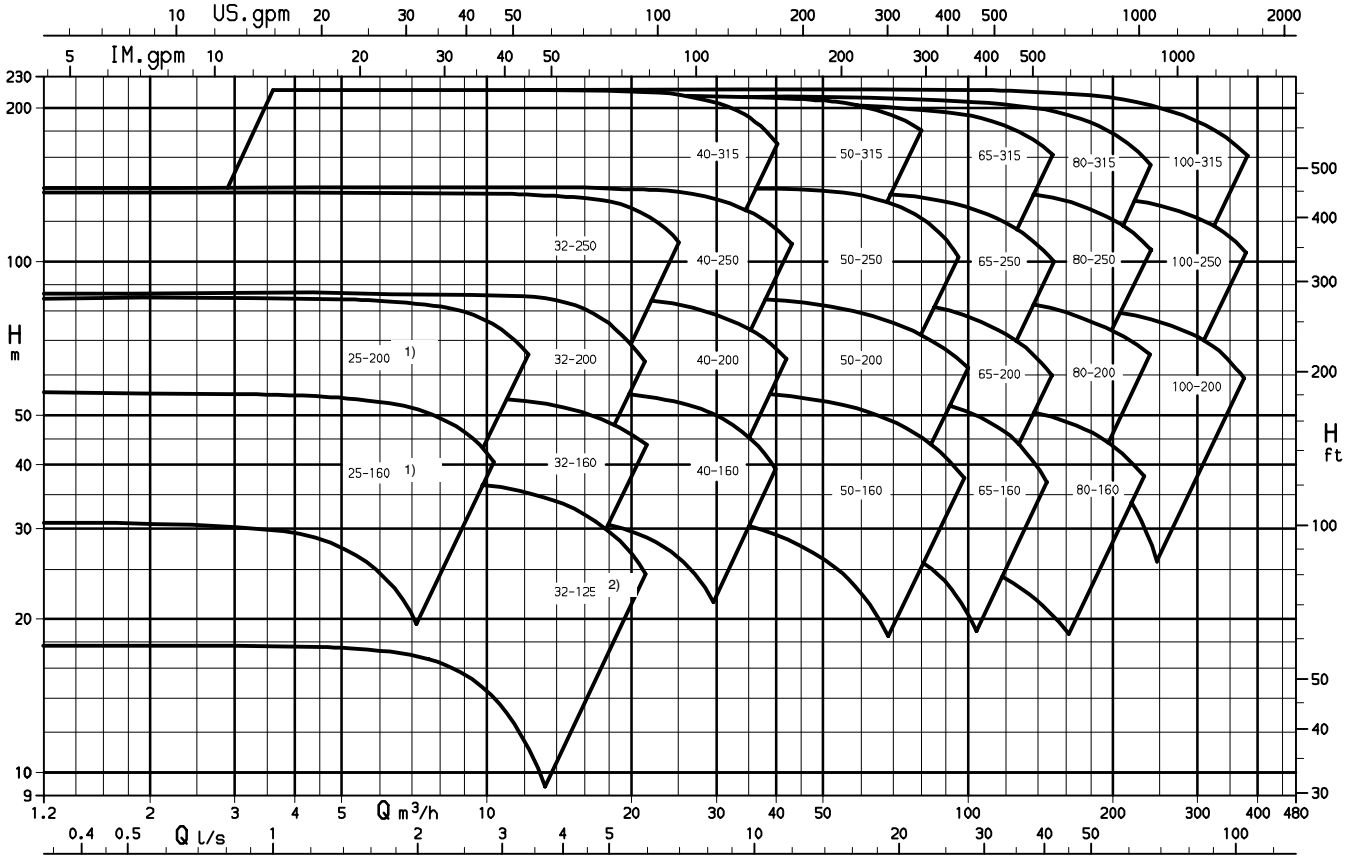

2721C.4062/1

n = 1750 rpm

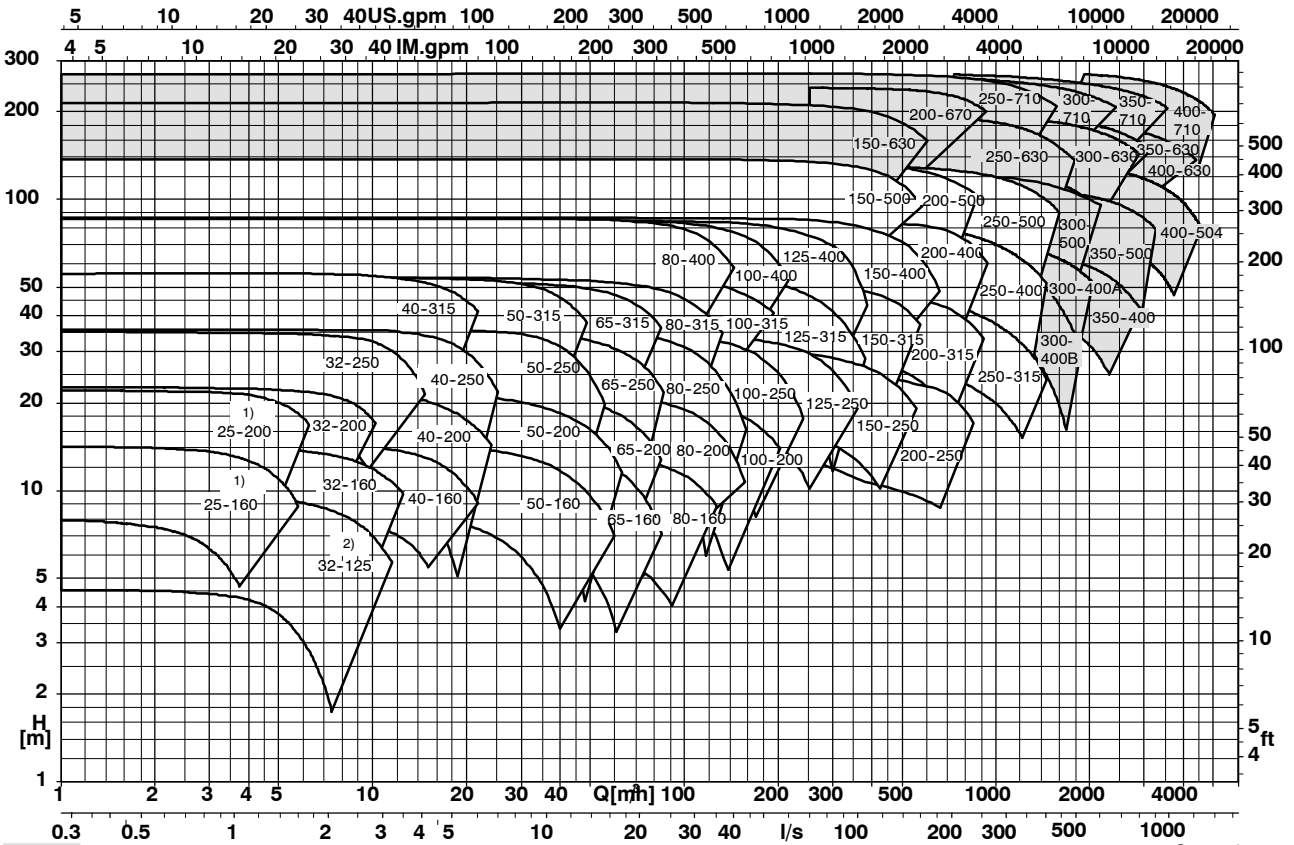

Complementary sizes on request

1121C.4064/2

- 1) HPK-S/-E4 not available in this size
- 2) HPK-E/-E4 not available in this size

Advantages at a Glance

Hydraulics:
nominal data and dimensions to ISO 2858/EN 22 858.

Impeller:
reduced axial thrust and shaft seal balancing due to back vanes.

Casing wear ring (HPK-S):
can be replaced.

Shaft:
not in contact with the fluid handled (dry shaft, therefore no special materials required).

Pressure-retaining parts:
safe design due to computerized strength analysis and quality casting with corrosion allowance.

Standardized modular design
ensures small stock of spare parts and fast delivery.

Back pull-out design:
the casing may remain in the pipeline when the pump is dismantled.

Flanges:
PN 25

Forcing screws
for easy dismantling.

Rotor and bearings
are dimensioned so as to ensure a shaft deflection below 0.05 mm and a bearing life of more than 17500 operating hours.

Fixed bearing:
minimum axial movement of rotor, fixed by shaft nut.

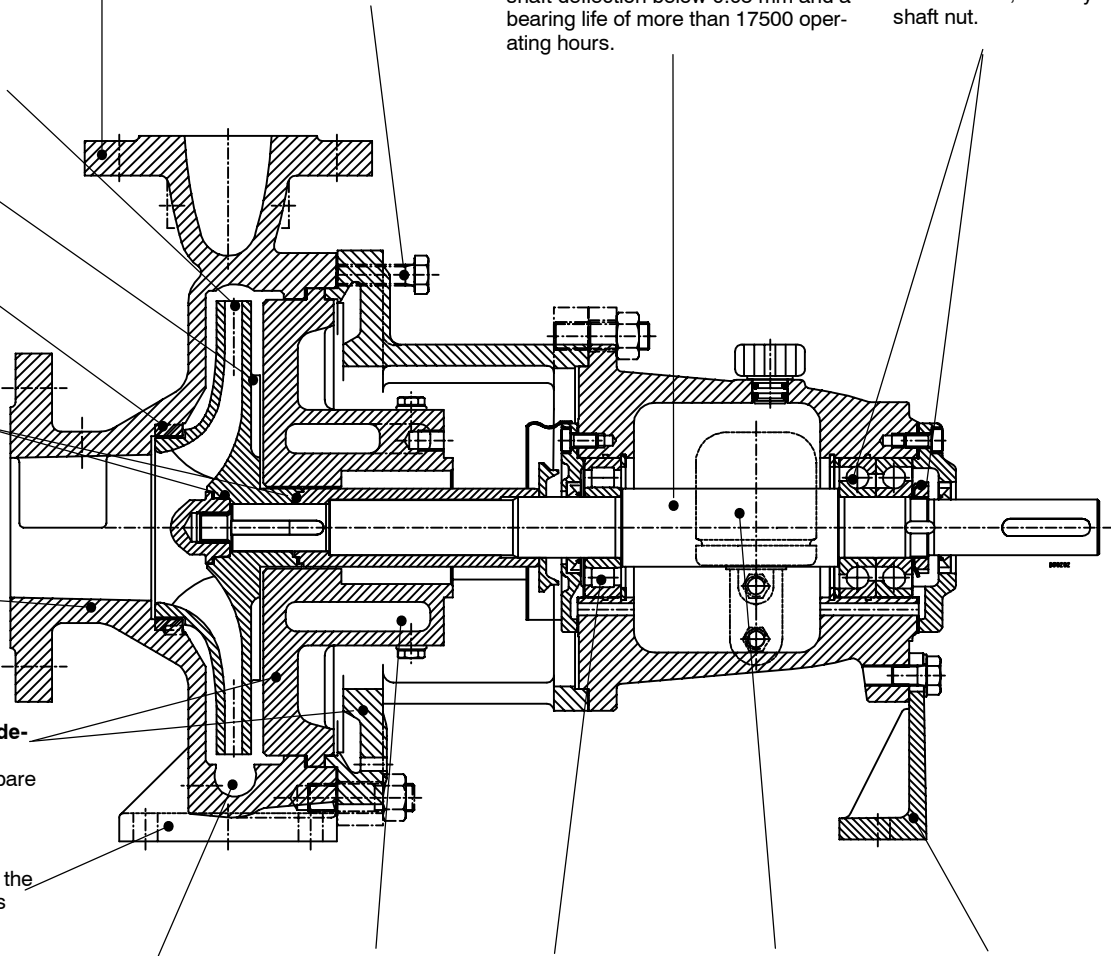

Volute
with low radial forces (double volute depending on pump size).

Intensive cooling

Radial bearing
permits easy assembly and absorbs thermal expansion of the shaft.

Constant-level oiler
ensures constant lubrication of the bearings and oil level monitoring.

Support foot:
Rigid and stable; even in the case of high external forces the shaft is only slightly displaced in the coupling area.

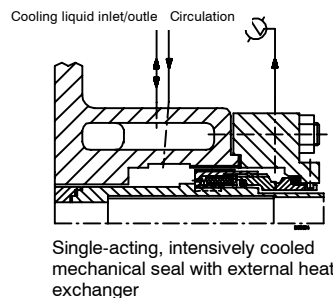
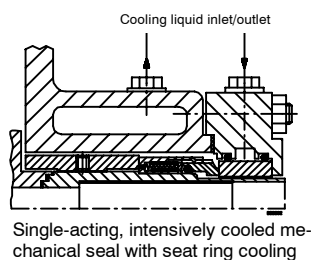
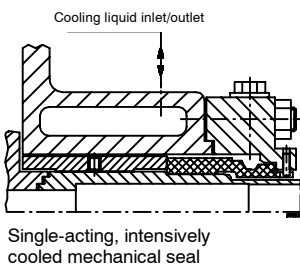
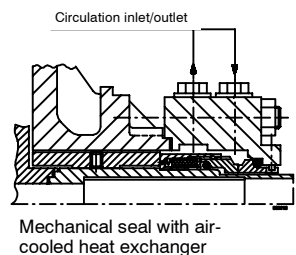
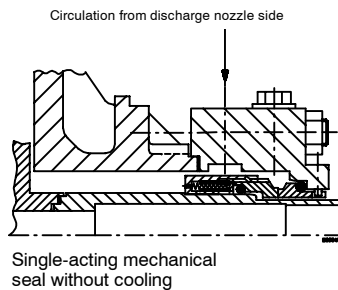
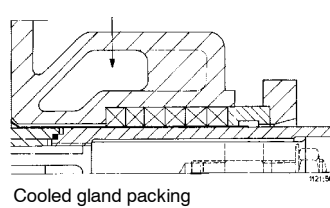
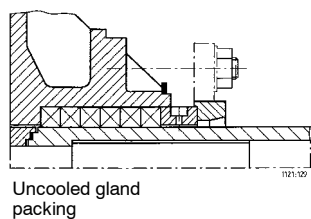

Technical Data
HPK-S/-E standard/HPK-E4 extended standard

		Units	Pump sizes																						
			25-160	25-200	32-125	32-160	32-200	40-160	40-200	50-160	50-200	32-250	40-250	40-315	50-250	50-315	65-160	65-200	65-250	80-160	80-200	80-250	100-200		
Bearing bracket			P 02as										P 03s												
General	Impeller outlet width	mm	6	6	8	7	7	9	7	15	12	6	7	8	10	8	20	16	13	27	22	17	29		
	Impeller inlet dia.	mm	45	45	52	52	52	65	65	82	82	52	65	65	84	84	89	96	96	100	114	114	122		
	Max. impeller dia.	mm	169	209	139	169	209	169	209	169	209	260	260	320	260	320	169	209	260	169	209	260	209		
	Min. impeller dia.	mm	130	160	100	130	160	130	160	130	160	200	200	260	200	260	130	160	200	130	160	200	160		
Shaft diameter	in stuffing box housing	mm	25										32												
	at bearings	pump end	35										35												
		motor end	35										35												
	at coupling	mm	24										32												
Shaft protecting sleeve dia.	Packing	mm	35 ¹⁾										45 ¹⁾												
Bearings	pump end	No.	NU 307										NU 307												
	motor end	No.	2 x 7307 BG										2 x 7307 BG												
Gland packing	Bore diameter	mm	51										65												
	Length	mm	53										64												
	Packing ring dimensions	mm	8 x 8										10 x 10												
	Number of packing rings	Qty.	6										6												
	Clearance for removal	mm	67										79												
Shaft deflection			Shaft deflection at the shaft seal of max. 0.05 mm complies with ISO 5199.																						
Pressure limits	Max. operating pressure	bar	25 / 40 ³⁾																						
	Max. test pressure	bar	1.5 times the max. permissible pump discharge pressure																						
Temperature limit	Max. temperature of pumped fluid	°C	240 depending on the shaft seal																						
Drive _{max.}	P/n values		0.009										0.021												

HPK-S/-E/-E4 extended standard

		Units	Pump sizes																						
			65-315	80-315	80-400	100-250	100-315	100-400	125-250	125-315	125-400	150-250	150-315	150-400	150-500	200-250	200-315	200-400	200-500	250-315	250-400	250-500			
Bearing bracket			P 04s										P 05s							P 06s					
General	Impeller outlet width	mm	10	14	11	23	19	15	32	26	20	46	38	29	23	62	50	40	32	73	63	43			
	Impeller inlet dia.	mm	96	129	118	129	135	129	154	154	154	180	190	190	190	190	222	222	222	270	294	280			
	Max. impeller dia.	mm	320	320	404	260	324	404	260	320	404	260	320	404	504	260	320	404	504	324	404	504			
	Min. impeller dia.	mm	260	260	320	200	260	320	200	260	320	200	260	320	400	200	260	320	400	260	320	400			
Shaft diameter	in stuffing box housing	mm	42										54							65					
	at bearings	pump end	55										65							65					
		motor end	55										65							75					
	at coupling	mm	42										48							60					
Shaft protecting sleeve dia.	Packing	mm	55 ¹⁾										70 ¹⁾							80 ¹⁾					
Bearings	pump end	No.	NU 311										NU 313							NU 413					
	motor end	No.	2 x 7311 BG										2 x 7313 BG 8							2 x 7315 BG 8					
Gland packing	Bore diameter	mm	75										95							105					
	Length	mm	64										79							79					
	Packing ring dimensions	mm	10 x 10										12.5 x 12.5							12.5x12.5					
	Number of packing rings	Qty.	6										6 ²⁾							6 ²⁾					
	Clearance for removal	mm	58										66							66					
Shaft deflection			Shaft deflection at the shaft seal of max. 0.05 mm complies with ISO 5199.																						
Pressure limits	Max. operating pressure	bar	25 / 40 ³⁾																						
	Max. test pressure	bar	1.5 times the max. permissible pump discharge pressure																						
Temperature limit	Max. temperature of pumped fluid	°C	240 depending on the shaft seal																						
Drive _{max.}	P/n values		0.05										0.11							0.2					

- 1) on variants with mechanical seal, slightly smaller in the mechanical seal area
- 2) if made of pure graphite, 5.5 rings
- 3) For E4 design

Casing

Radially split, consisting of volute casing and discharge cover. HPK-S with casing wear ring, HPK-E without casing wear ring. Double volute depending on the pump size.

Balancing

Axial thrust is balanced by means of back vanes.

Shaft Seal

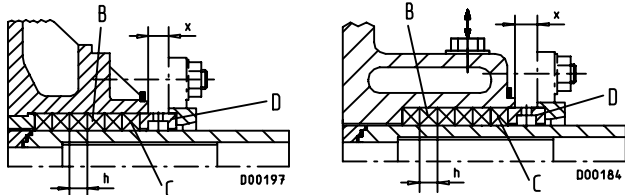

uncooled

cooled

Uncooled shaft seal: pure graphite packings up to +185 °C (if cooled, up to +240 °C) or Teflon/graphite packings up to +160 °C (if cooled, up to +190 °C). Slight leakage (some cm³/min) is unavoidable.

Not recommended for speed-controlled pumps.

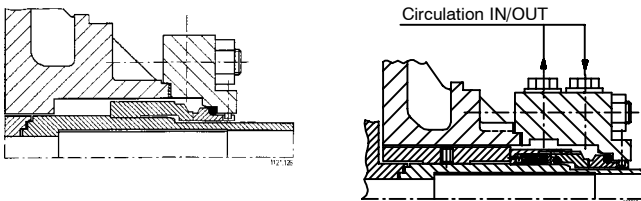

Uncooled shaft seal: single-acting, balanced mechanical seal up to +160 °C; with external air-cooled heat exchanger up to +200 °C. Water treatment to VdTÜV regulation TCH 1466/AGFW 5-15.

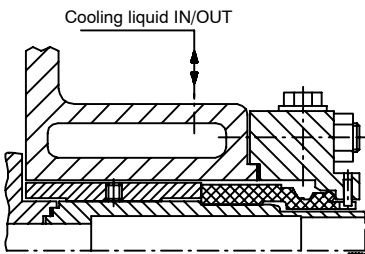

Cooled shaft seal: single-acting, balanced mechanical seal up to +190 °C. The shaft seal chamber is cooled via the seal housing; vented through throttling gap. Water treatment to VdTÜV regulation TCH 1466/AGFW 5-15.

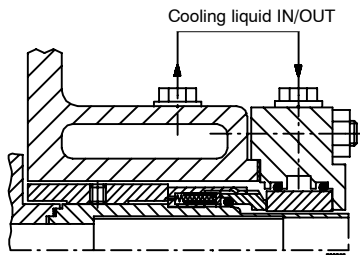

Cooled shaft seal: single-acting, balanced mechanical seal up to +210 °C. The shaft seal chamber is cooled via the seal housing and coolable seat ring; vented through throttling gap. Water treatment to VdTÜV regulation TCH 1466/AGFW 5-15.

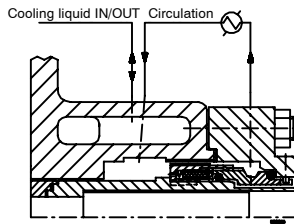

Cooled shaft seal: single-acting, balanced mechanical seal up to +240 °C (max.). The seal chamber is cooled via the stuffing box housing and product circulation through an external heat exchanger (pumping screw). Water treatment to VdTÜV regulation TCH 1466/AGFW 5-15.

Tests

Materials tests on the components:

Test report 2.2 upon request, regarding

- chemical composition
- heat treatment
- tensile test
- notched bar impact test (only for tough materials)
- hardness test
- non-destructive tests

Product inspection on the unit:

Inspection certificate 3.1 B upon request, for

- pressure test of the complete pump to EN 10204
- hydraulic test run to ISO 9906/2A, 5 measuring points
- NPSH test

Documentation

Documentation in accordance with EC requirements

- Sectional drawing with list of components
- Mechanical seal drawing
- Installation plan / dimension table
- Operating instructions
- Starting torques

Coating

Standard coating acc. to works standard AN 1865

< 150 °C	N	1	1	1	W
≥ 150 °C	N	7	7	7	W

Raw part treatment	_____	_____	_____	_____	_____
Coating of pump	_____	_____	_____	_____	_____
Coating of baseplate and bearing bracket	_____	_____	_____	_____	_____
Coating of motor	_____	_____	_____	_____	_____
Preservation	_____	_____	_____	_____	_____

N = raw part treatment

1 = RAL 5002, blue

7 = heat-resistant silicone-free paint, RAL 9007 aluminium grey

W = flushed with water-repellent agent; blank parts liable to rust with protective coating

Packaging

Standard packaging:

on boards	if pump alone
on skid rails/crossbars	if pump is mounted on baseplate

Plates/Labels

All labels and plates are available in the following languages (please specify in the purchase order):

German, English, French, Spanish, Italian, Danish, Greek, Dutch, Swedish or Portuguese.

Forces and Moments

HPK pumps are designed so as to withstand forces and moments in accordance with ISO 5199.

Recommended Stock of Spare Parts for 2 Years' Operation to DIN 24 296

Part No.	Description	Number of pumps (incl. standby pumps)							
		2	3	4	5	6+7	8+9	10 and more	
		Quantity of spare parts							
210	Shaft	1	1	1	2	2	2	20 %	
230	Impeller	1	1	1	2	2	2	20 %	
320.02	Angular contact ball bearing (set)	1	1	2	2	2	3	25 %	
322.01	Cylindrical roller bearing	1	1	2	2	2	3	25 %	
433	Mechanical seal	1	1	2	2	2	3	25 %	
	or								
	spring-loaded ring	2	3	4	5	6	7	90 %	
	seat ring	2	3	4	5	6	7	90 %	
	secondary seal at spring-loaded ring	2	3	4	5	7	9	100 %	
	secondary seal at seat ring	2	3	4	5	7	9	100 %	
	spring (set)	1	1	1	1	2	2	20 %	
456.01	Neck bush	1	1	2	2	2	3	30 %	
461.01	Gland packing (set)	4	4	6	6	6	8	100 %	
502.01	Casing wear ring	2	2	2	3	3	4	50 %	
524.01	Shaft protecting sleeve	2	2	2	3	3	4	50 %	
---	Gaskets for pump casing (set)	4	6	8	8	9	12	150 %	
---	Torque transmission elements (coupling, set)	1	1	2	2	3	4	30 %	

Dimensions

HPK-S/-E Standard
HPK-E4 extended standard

y = dismantling clearance (without removing the motor)

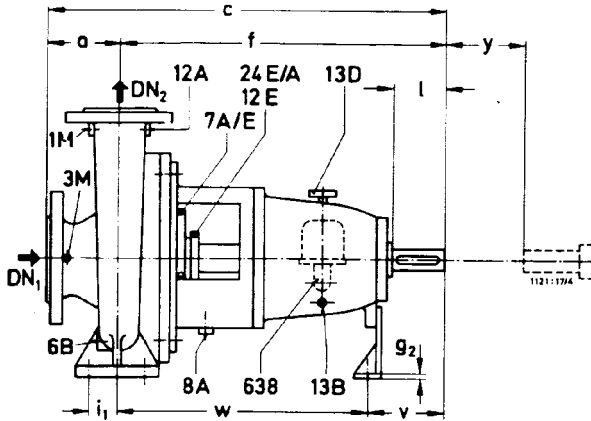

Flange design

- HPK-S EN 1092-2, PN 25
- HPK-E EN 1092-1, PN 25
- HPK-E4 EN 1092-1, PN 40

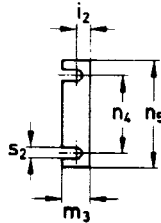
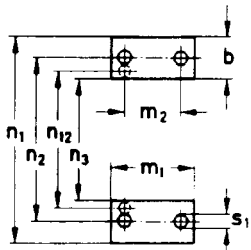
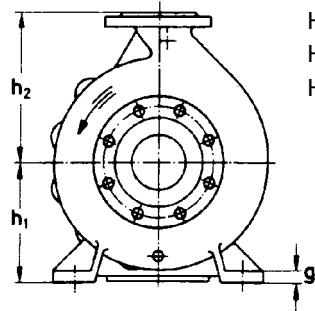

Shaft end

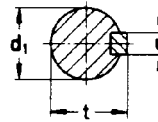

Key according to DIN 6885-1

Dimensions in mm

Pump size	Bearing bracket	Pump dimensions															Shaft end					Foot bolts								
		DN ₁	DN ₂	a	b	c	f	g ₁	g ₂	h ₁	h ₂	m ₁	m ₃	n ₁	n ₃	n ₅	d ₁ k ₆	l	t	u	y	i ₁	i ₂	m ₂	n ₂	n ₄	s ₁	s ₂	v	w
25-160 ¹⁾	P 02as	40	25	80	50	465	385	14	8	132	160	100	45	240	140	160	24	50	27	8	100	35	28	70	190	110	14	14	100	285
25-200 ¹⁾	P 02as			80	50	465	385	14	8	160	180	100	45	240	140	160	24	50	27	8	100	35	28	70	190	110	14	14	100	285
32-125 ²⁾	P 02as	50	32	80	50	465	385	12	8	112	140	100	45	190	90	160	24	50	27	8	100	35	28	70	140	110	14	14	100	285
32-160	P 02as			80	50	465	385	14	8	132	160	100	45	240	140	160	24	50	27	8	100	35	28	70	190	110	14	14	100	285
32-200	P 02as			80	50	465	385	14	8	160	180	100	45	240	140	160	24	50	27	8	100	35	28	70	190	110	14	14	100	285
32-250	P 03s			100	65	600	500	16	8	180	225	125	47	320	190	160	32	80	35	10	100	47,5	30	95	250	110	14	14	130	370
40-160	P 02as	65	40	80	50	465	385	14	8	132	160	100	45	240	140	160	24	50	27	8	100	35	28	70	190	110	14	14	100	285
40-200	P 02as			100	50	485	385	14	8	160	180	100	45	265	165	160	24	50	27	8	100	35	28	70	212	110	14	14	100	285
40-250	P 03s			100	65	600	500	16	8	180	225	125	47	320	190	160	32	80	35	10	100	47,5	30	95	250	110	14	14	130	370
40-315	P 03s			125	65	625	500	18	8	200	250	125	47	345	215	160	32	80	35	10	100	47,5	30	95	280	110	14	14	130	370
50-160	P 02as	80	50	100	50	485	385	14	8	160	180	100	45	265	165	160	24	50	27	8	100	35	28	70	212	110	14	14	100	285
50-200	P 02as			100	50	485	385	14	8	160	200	100	45	265	165	160	24	50	27	8	100	35	28	70	212	110	14	14	100	285
50-250	P 03s			125	65	625	500	16	8	180	225	125	47	320	190	160	32	80	35	10	100	47,5	30	95	250	110	14	14	130	370
50-315	P 03s			125	65	625	500	18	8	225	280	125	47	345	215	160	32	80	37	10	100	47,5	30	95	280	110	14	14	130	370
65-160	P 03s	100	65	100	65	600	500	15	8	160	200	125	47	280	150	160	32	80	35	10	100	47,5	30	95	212	110	14	14	130	370
65-200	P 03s			100	65	600	500	16	8	180	225	125	47	320	190	160	32	80	35	10	140	47,5	30	95	250	110	14	14	130	370
65-250	P 03s			125	80	625	500	18	8	200	250	160	47	360	200	160	32	80	35	10	140	60	30	120	280	110	18	14	130	370
80-160	P 03s	125	80	125	65	625	500	15	8	180	225	125	47	320	190	160	32	80	35	10	140	47,5	30	95	250	110	14	14	130	370
80-200	P 03s			125	65	625	500	16	8	180	250	125	47	345	215	160	32	80	35	10	140	47,5	30	95	280	110	14	14	130	370
80-250	P 03s			125	80	625	500	18	8	225	280	160	47	400	240	160	32	80	35	10	140	60	30	120	315	110	18	14	130	370
100-200	P 03s	125	100	125	80	625	500	16	8	200	280	160	47	360	200	160	32	80	35	10	140	60	30	120	280	110	18	14	130	370

1) HPK-S/E4 not available in this size
2) HPK-E/E4 not available in this size

Dimensions

HPK-S/-E extended Standard

y = dismantling clearance (without removing the motor)

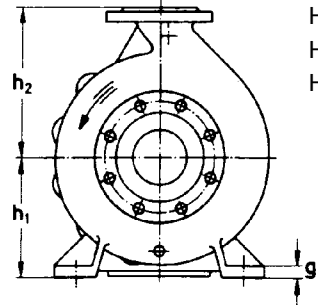
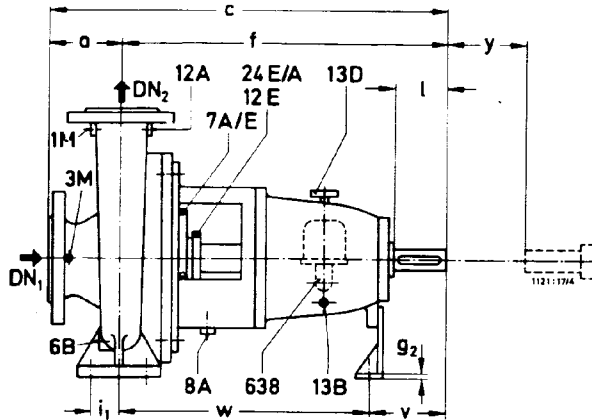

Flange design
 HPK-S EN 1092-2, PN 25
 HPK-E EN 1092-1, PN 25
 HPK-E4 EN 1092-1, PN 40

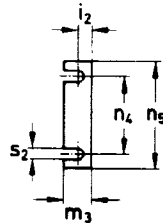
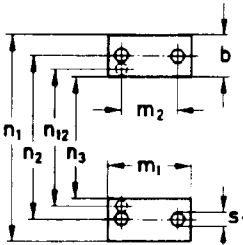

Shaft end

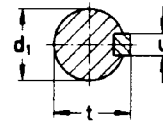

Key according to DIN 6885-1

Dimensions in mm

Pump size	Bear- ing bracket	Pump dimensions															Shaft end					Foot bolts								
		DN ₁	DN ₂	a	b	c	f	g ₁	g ₂	h ₁	h ₂	m ₁	m ₃	n ₁	n ₃	n ₅	d ₁ ø k ₆	l	t	u	y	i ₁	i ₂	m ₂	n ₂	n ₄	s ₁	s ₂	v	w
65-315	P 04s	100	65	125	80	655	530	18	12	225	280	160	52	400	240	160	42	110	45	12	140	60	33	120	315	110	18	14	160	370
80-315	P 04s	125	80	125	80	655	530	18	12	250	315	160	52	400	240	160	42	110	45	12	140	60	33	120	315	110	18	14	160	370
80-400	P 04s			125	80	655	530	20	12	280	355	160	52	435	275	160	42	110	45	12	140	60	33	120	355	110	18	14	160	370
100-250	P 04s			140	80	670	530	18	12	225	280	160	52	400	240	160	42	110	45	12	140	60	33	120	315	110	18	14	160	370
100-315	P 04s	125	100	140	80	670	530	18	12	250	315	160	52	400	240	160	42	110	45	12	140	60	33	120	315	110	18	14	160	370
100-400	P 04s			140	100	670	530	20	12	280	355	200	52	500	300	160	42	110	45	12	140	75	33	150	400	110	23	14	160	370
125-250	P 04s			140	80	670	530	18	12	250	355	160	52	400	240	160	42	110	45	12	140	60	33	120	315	110	18	14	160	370
125-315	P 04s	150	125	140	100	670	530	20	12	280	355	200	52	500	300	160	42	110	45	12	140	75	33	150	400	110	23	14	160	370
125-400	P 04s			140	100	670	530	20	12	315	400	200	52	500	300	160	42	110	45	12	140	75	33	150	400	110	23	14	160	370
150-250	P 04s			160	100	690	530	20	12	280	375	200	52	500	300	160	42	110	45	12	180	75	33	150	400	110	23	14	160	370
150-315	P 05s	200	150	160	100	830	670	22	12	315	400	200	60	550	350	200	48	110	51	14	180	75	39	150	450	140	23	18	170	500
150-400	P 05s			160	100	830	670	22	12	315	450	200	60	550	350	200	48	110	51	14	180	75	39	150	450	140	23	18	170	500
150-500	P 05s	200	150	180	100	850	670	22	12	375	500	200	60	550	350	200	48	110	51	14	180	75	39	150	450	140	23	18	170	500
200-250	P 05s	200		180	100	850	670	22	12	355	425	200	60	550	350	200	48	110	51	14	180	75	39	150	450	140	23	18	170	500
200-315	P 05s	250	200	200	110	870	670	22	12	355	450	200	60	550	350	200	48	110	51	14	180	75	39	150	450	140	23	18	170	500
200-400	P 05s	250		180	100	850	670	22	12	355	500	200	60	550	350	200	48	110	51	14	180	75	39	150	450	140	23	18	170	500
200-500	P 05s	250		200	100	870	670	22	12	425	560	200	60	660	460	200	48	110	51	14	180	75	39	150	560	140	23	18	170	500
250-315	P 05s			250	130	920	670	26	12	400	560	260	60	690	430	200	48	110	51	14	180	95	39	190	560	140	28	18	170	500
250-400	P 06s	300	250	200	130	920	720	26	12	425	600	260	60	800	540	200	60 ¹⁾	140	64	18	180	95	39	190	670	140	28	18	205	515
250-500	P 06s			200	130	920	720	26	12	475	670	260	60	800	540	200	60 ¹⁾	140	64	18	180	95	39	190	670	140	28	18	205	515

1) d₁ Ø_{n6}

When ordering spare parts, please always specify:

Type series/pump size, order No. (stamped on the name plate and on the suction nozzle flange), motor No. (serial No.), year of construction, quantity required, part No., description, material, fluid handled, general assembly drawing No. and mode of dispatch.

Part No.	Description	Scope of supply
102	Volute casing	with joint ring 411.01/.02/.03/.04/10, casing wear ring 502.01 ¹⁾ , parallel pin 561.01 ¹⁾ , stud 902.01, screwed plug 903.01/.02/.03/.04, hex. nut 920.01
161	Casing cover	with joint ring 411.18/.19, drip plate 463.01, disc 550.01, stud 902.02, screwed plug 903.18/.19, hex. nut 920.02
183	Support foot	with hex. head bolt 901.04 ²⁾ , spring washer 930.01
210	Shaft	with keywayed nut 920.21, lockwasher 931.01, key 940.01/.02
230	Impeller	with joint ring 411.32
320.02	Angular contact ball bearing	
322.01	Cylindrical roller bearing	
330	Bearing bracket	
330	Bearing bracket (complete)	with bearing cover 360.01/.02, gasket 400.01/.02, joint ring 411.46, radial shaft seal ring 421.01/.02, thrower 507.1, supporting disc 550.23, constant-level oiler 638, vent plug 672, screwed plug 903.46, socket head cap screw 914.01/.02, circlip 932.01/.02
344	Bearing bracket lantern	with stud 902.04, hex. head bolt 901.31, hex. nut 920.04
360.01/.02	Bearing cover	with gasket 400.01/.02, socket head cap screw 914.01/.02
421.01/.02	Radial shaft seal ring	
452.01	Gland	
454.01	Stuffing box ring	split
461.01	Gland packing	
463.01	Drip plate	
502.01 ¹⁾	Casing wear ring	with parallel pin 561.01
507.01	Thrower	
524.01	Shaft protecting sleeve	with joint ring 411.32
638	Constant-level oiler	
680	Guard	
922	Impeller nut	with joint ring 411.31

1) only for HPK-S

2) on bearing bracket P 02a / P 02as / P04as: socket head cap screw 914.04

